



# Track & Ring Conditioner

## Assembly Instructions

*For all models*



**System Equine**

14321 Fifth Line Nassagaweya • Rockwood, ON • N0B 2K0

1 (800) 461-3362 • [Sales@SystemEquine.com](mailto:Sales@SystemEquine.com)

[SystemEquine.com](http://SystemEquine.com)

# TRACK & RING CONDITIONER ASSEMBLY INSTRUCTIONS FOR

## READ ALL INSTRUCTIONS BEFORE STARTING ASSEMBLY PROCESS!

First before you start be sure to unpack all the components be careful not to damage the boxes as you will need them to aid in the assembly. Check that you have all the required components and hardware for your model compare to the parts list and photo to the right.

### LIST OF TOOLS REQUIRED TO COMPLETE ASSEMBLY.

You will require two of each of these wrench sizes: 9/16" wrenches, 3/4" wrenches, 15/16" wrenches, 1 1/8" wrenches and a medium size hammer if you have a pull-behind model. See photo below. An adjustable wrench and a socket set will also work.

Familiarize yourself with the names of the components and hardware. See photo.

### TOOLS REQUIRED

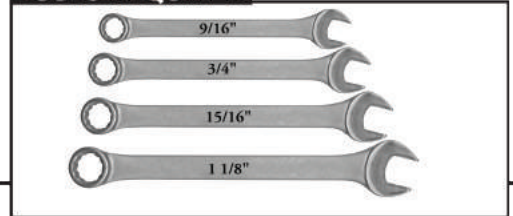

## TRACK & RING CONDITIONER PARTS LIST

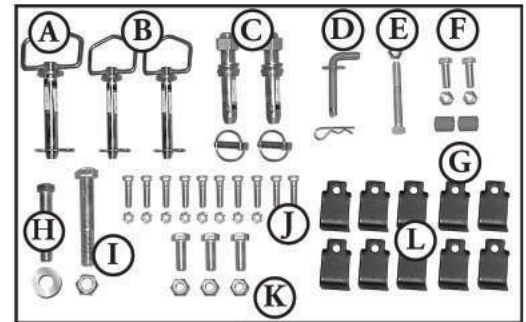
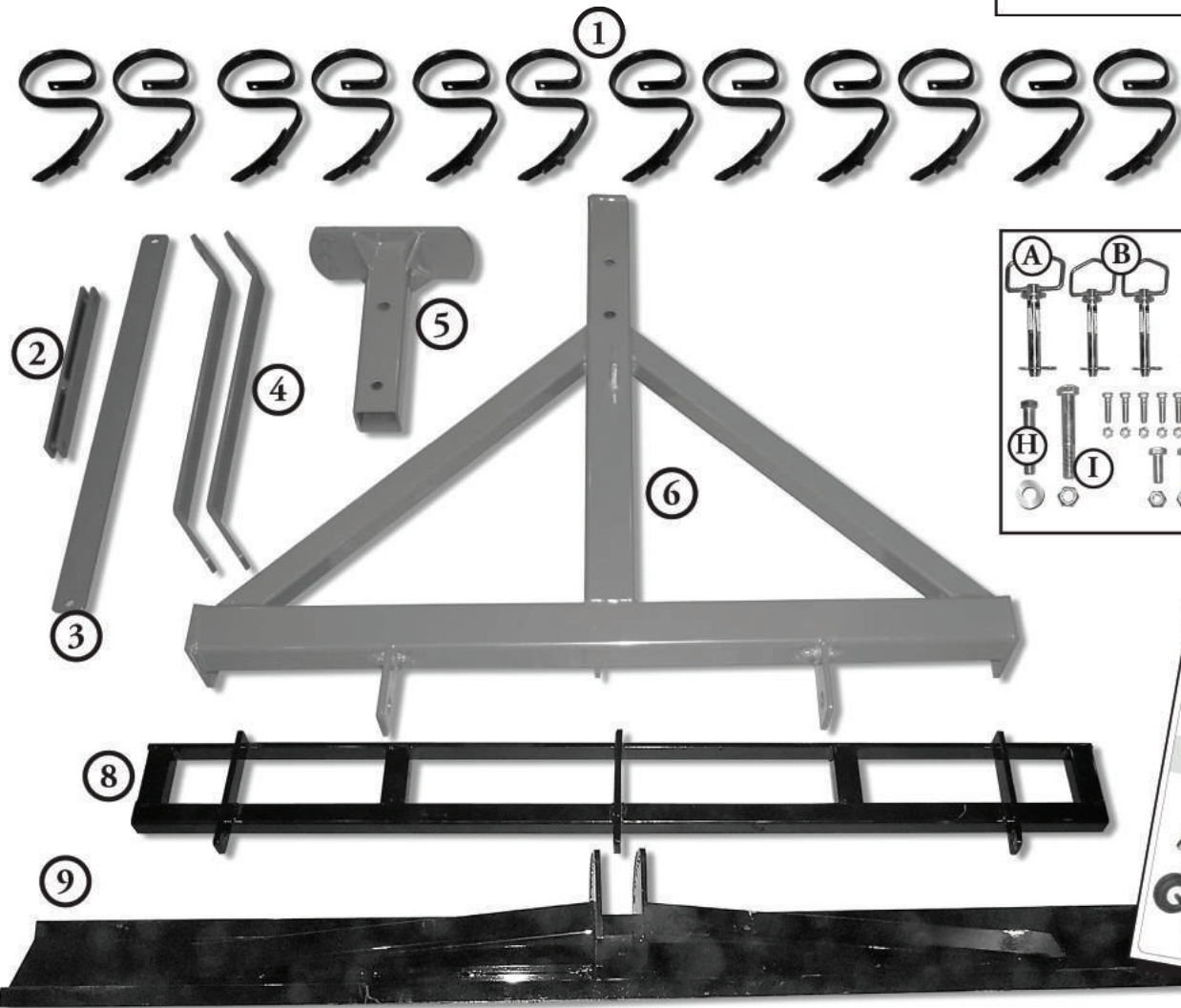

ID	PART #	DESCRIPTION	QTY 6'	QTY 8'	ID	PART #	DESCRIPTION	QTY 6'	QTY 8'
1	TRC8-1	Tine Assembly with Points (6.5")	10	12	A	TRC-P3/4	3/4" x 4 1/4" Hitch Pin for Blade Angle Adjustment	2	2
2	TRC-HB	Adjuster Bar	1	1	B	TRC-P3/4	3/4" x 4 1/4" Hitch Pin for 3 Point Hitch	1	1
3	TRC-SB	Straight Bar	1	1	C	TRC LIFT PIN	Lift Arm Pin Cat I 7/8" x 5 1/2"	2	2
4	TRC-SBB	S-Bar	2	2	D	TRC-P1/2	Pin 1/2 with Clip	1	1
5	TRC-BP	Blade Post	1	1	E	02-2137	Hex Bolt 1/2" x 4" Hot Dipped Galv G5 with Lock...	1	1
6	TRC-AF	A-Frame	1	1	F	02-2125	Hex Bolt 1/2" x 1 1/2" Hot Dipped Galv G5 with...	2	2
7		Assembly Manual	1	1	G	TRC-S1	Spacer 1"	2	2
8	TRC-TB5	Tine Bar 5'	1	1	H	02-2157	Hex Bolt 3/4" 4 1/2" Hot Dipped Galv G5	1	1
8.1	TRC-TB7	Tine Bar 7'			I	02-2158	Hex Bolt 3/4" x 5" Zinc G5 with Lock Nut	1	1
9	TRCBLADE6	Blade 6'	1	1	J	02-2111	Hex Bolt 3/8" x 1 1/2" Hot Dipped Galv G5 with...	10	12
9.1	TRCBLADE8	Blade 8'			K	02-2147	Hex Bolt 5/8" 2" Zinc G5 with Lock Nut	3	3
					L	TRCTINE	Tine Brackets	10	12

# MODELS: TRC-6 / TRC-8 / TRC-PULL-BEHIND-6 & 8

## TRACK & RING CONDITIONER ASSEMBLY INSTRUCTIONS

### STEP 1 TINE BAR ASSEMBLY

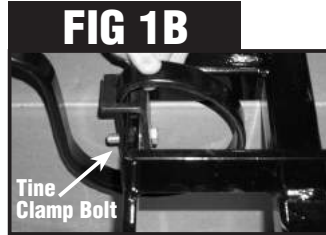
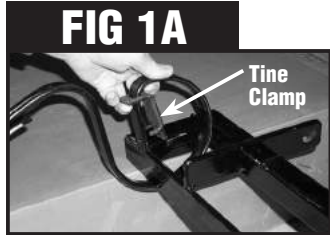
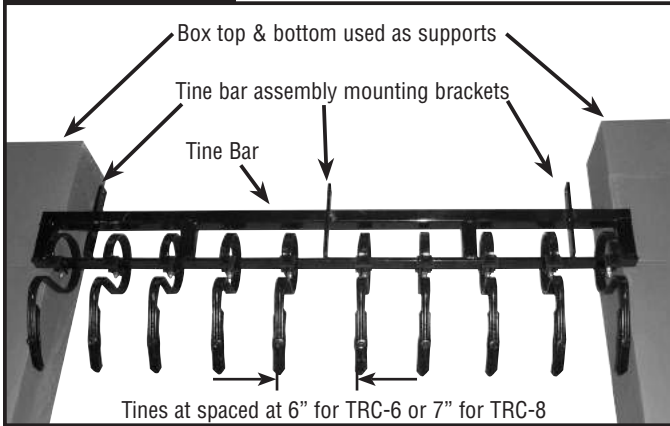

### STEP 1 INSTALLING TINES ON TINE BAR

See fig. **STEP 1** photo before proceeding.

1. Place tine bar between two supports as shown in **STEP 1** photo (we used the top and bottom of the shipping boxes anything that will give you at least 8" clearance will do.)
2. Place first tine on tine bar as shown in **FIG 1A** & **FIG 1B**. Attach and tighten using 3/8" x 1 1/2" bolts and lock nuts. Repeat process until all tines are in place.

**NOTE:** Tines should be spaced approximately 6" apart on center for the TRC-6 and 7" for a TRC-8.

*THIS FINISHED SECTION WILL BE CALLED THE **TINE BAR ASSEMBLY**.*

### STEP 2 BLADE POST & BLADE

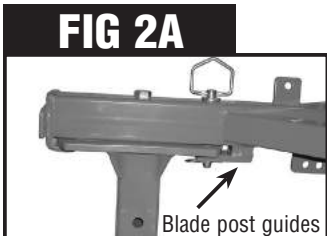
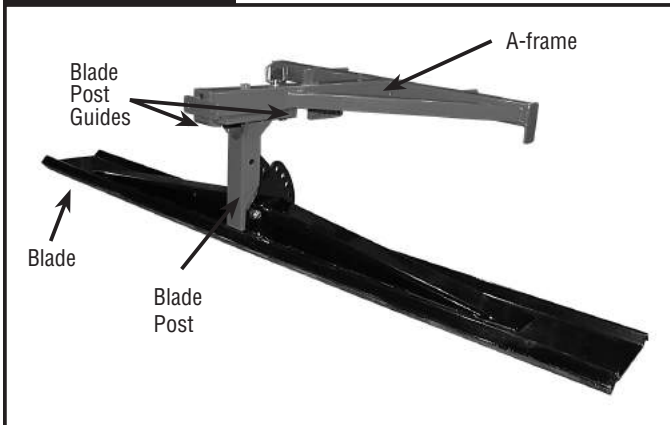

### STEP 2 ATTACHING THE BLADE POST AND BLADE TO THE A-FRAME

See **STEP 2** photo before proceeding

1. Position the blade post in the guides on the rear of the A-frame with blade angle adjustment holes facing towards the front of the A-frame as shown **FIG 2A**.
2. Using a 3/4" x 4 1/2" bolt put flat washer on bolt and put bolt through A-Frame hole sliding into top of centre Blade Post hole. Tighten using 1 1/8" wrench or ratchet & socket. **NOTE:** There is a nut is welded on to bottom side of Blade Post Plate. (Make sure that the front hitch pin is in front hole so Blade Post does not turn.)
3. Tighten the bolt and nut completely and then back off 1/4 turn to allow for movement of the blade post.
4. Then drop in the 3/4" drop pin through the A-frame into a blade post adjustment hole. Next position the blade face down and lift the blade post and A-frame placing it into the slot on the back of the blade, and attach using the 3/4" x 5" bolt and lock nut **FIG 2B**. Again tighten completely and back off 1/4 turn to allow for movement. **NOTE:** leave blade assembly unfinished at this time this will make the unit more stable for the rest of the assembly.

### STEP 3 3 POINT HITCH ASSEMBLY

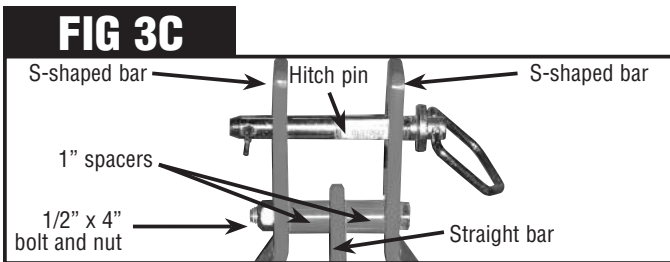
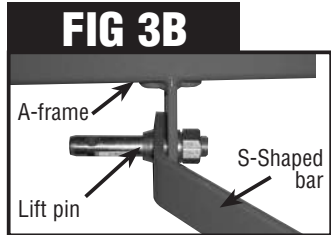
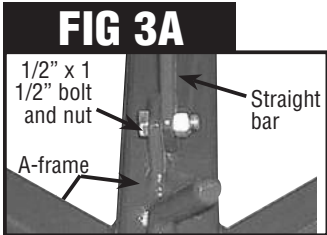
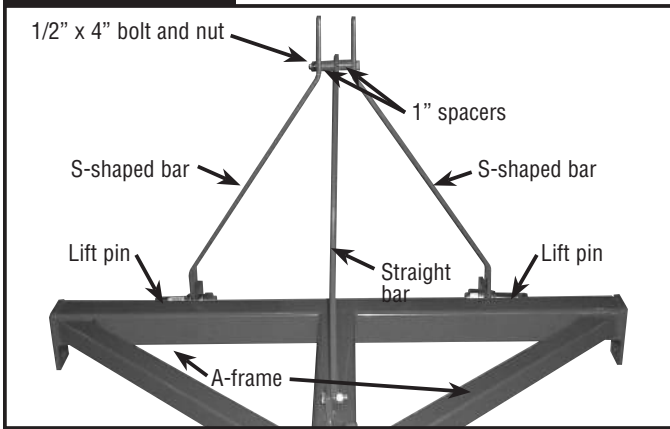

### STEP 3 ATTACHING THE 3 POINT HITCH

See **STEP 3** photo before proceeding

1. First fasten the straight bar to the A-frame with a 1/2"x 1 1/2" bolt & lock nut **FIG 3A**.
2. Then locate and fasten the two S-shape hitch bars to the A-frame with the lift pins as shown **FIG 3B**.
3. Now take the unfastened ends of the S-shaped bar and straight bar and using the 1/2" X 4" bolt & nut with the 1" spacers on either side of the straight bar join the 3 ends as shown in **FIG 3C**.
4. Tighten these bolts now before proceeding.
5. Then install the hitch pin and fasten with the cotter pin.

**NOTE:** There will be approximately 1/4" of play around the hitch pin this is normal.

### STEP 4 TINE BAR TO A-FRAME

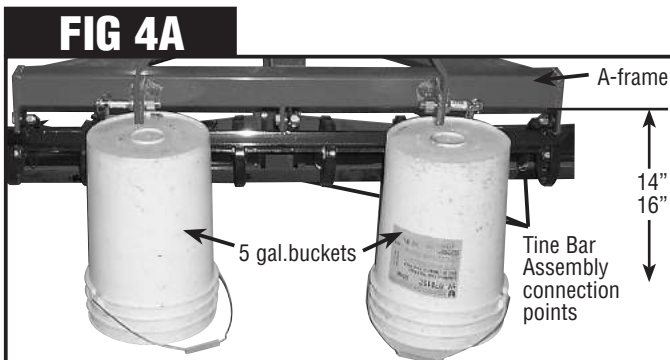
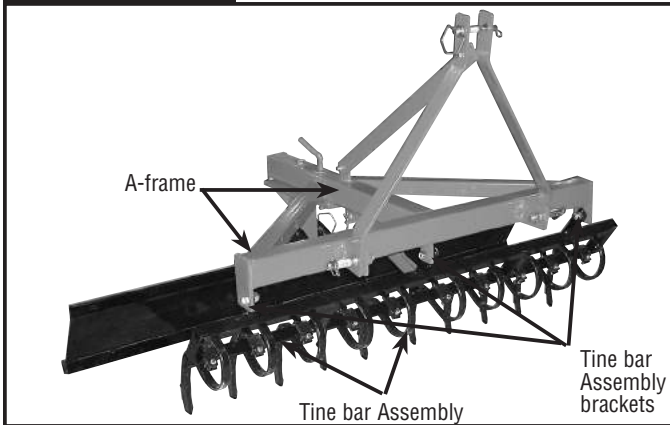

**NOTE:** Tine bar needs to swing freely from A-frame connection points. Tighten the bolts and back off each bolt 1/4 turn or until tine bar assembly moves freely.

### STEP 4 ATTACHING THE TINE BAR ASSEMBLY TO THE A-FRAME

See **STEP 4** photo before proceeding

1. Support the front of the A-frame at an approximate height of 14" to 16" (we used two 5 gallon buckets) place the buckets or whatever you choose under the 3 point hitch brackets at the front of the A-frame **FIG 4A**.
- NOTE:** Keep supports clear of A-frame. **IMPORTANT:** make sure A-frame is supported securely.
2. Now slide the tine bar assembly into position under the A-frame with the tines pointing down and towards the blade at the back. **FIG 4B**
3. With help attach the tine bar assembly with the 5/8" x 2" bolts & lock nuts to the 3 mounting brackets on the under side of the A-frame.
4. Tighten the bolts and back off 1/4 turn to allow tine bar assembly to move freely.

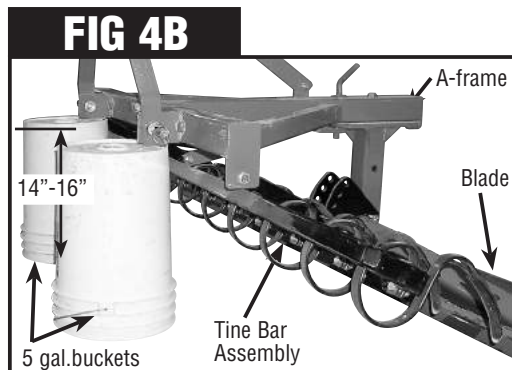

## STEP 5 TINE HEIGHT ADJUSTMENT

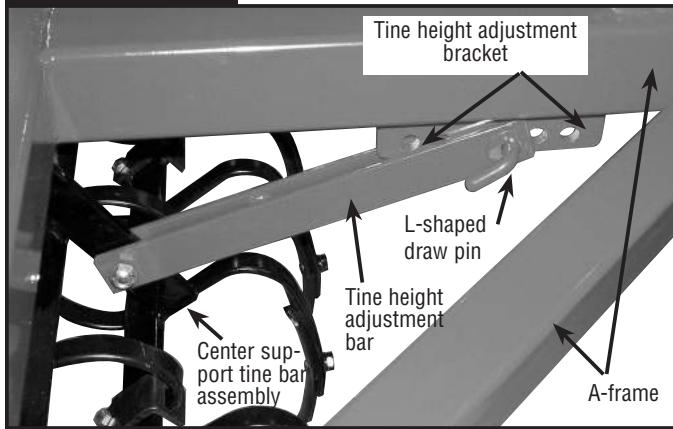

## STEP 5 ATTACHING THE TINE HEIGHT ADJUSTMENT BAR

See **STEP 5** photo before proceeding

1. Locate the tine height adjustment bar and fasten to the center support of the tine bar assembly using the 1/2" x 1 1/2" bolt & lock nut **STEP 5** photo.
2. Lift and attach the other end to the center hole of the tine height adjustment bracket attached to the under side of the A-frame using one of the 5/8" x 4 1/2" hitch pins and secure in place with the cotter pin.

## STEP 6 BLADE POSITION

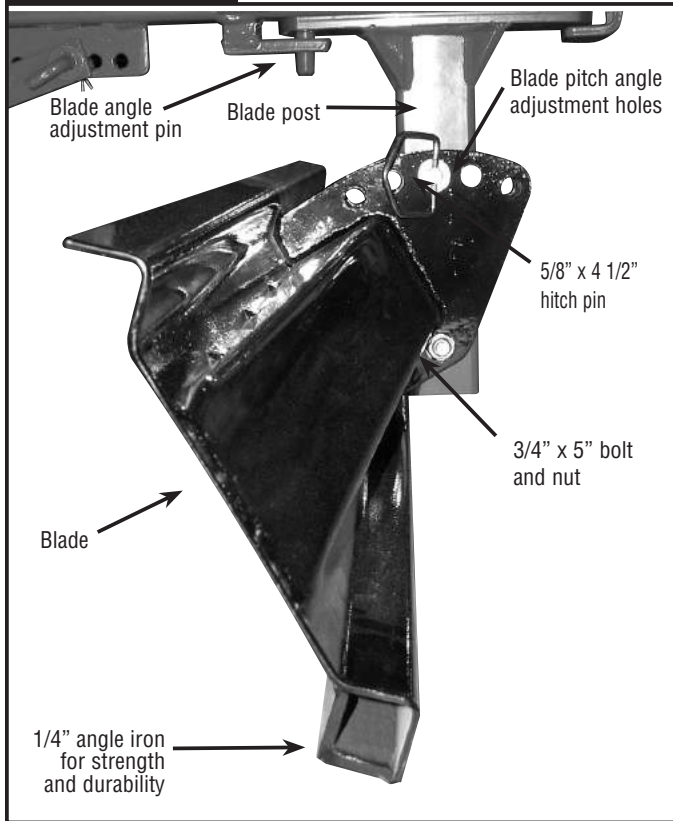

## STEP 6 FINALIZING BLADE POSITION

See **STEP 6** photo before proceeding

1. Lift the blade from either side until the center blade pitch angle adjustment hole is lined up with the hole in the blade post. Then secure in position with the remaining 5/8" x 4 1/2" hitch pin.

## ATTACHING THE TRACK AND RING CONDITIONER USING THE 3 POINT HITCH ASSEMBLY

## STEP 6 ATTACHING TO THE TRACTOR

1. Backup your tractor with a 3 point hitch to the Track Conditioner. Make sure the area is clear of people and animals.
2. Position the tractor so the lift arms line up with the lift pins on the conditioner.
3. Slide the lift arms over the lift pins and put on the clip pins.
4. Attach the top link supplied with your tractor to top of the three point hitch with the hitch pin supplied.
5. Adjust to the top link until the "A" Frame of the conditioner is level.

See operation instructions on last page for proper use of your Track and Ring Conditioner.

# OPTIONAL PULL-BEHIND ATTACHMENT ASSEMBLY

## PULL-BEHIND HITCH PARTS

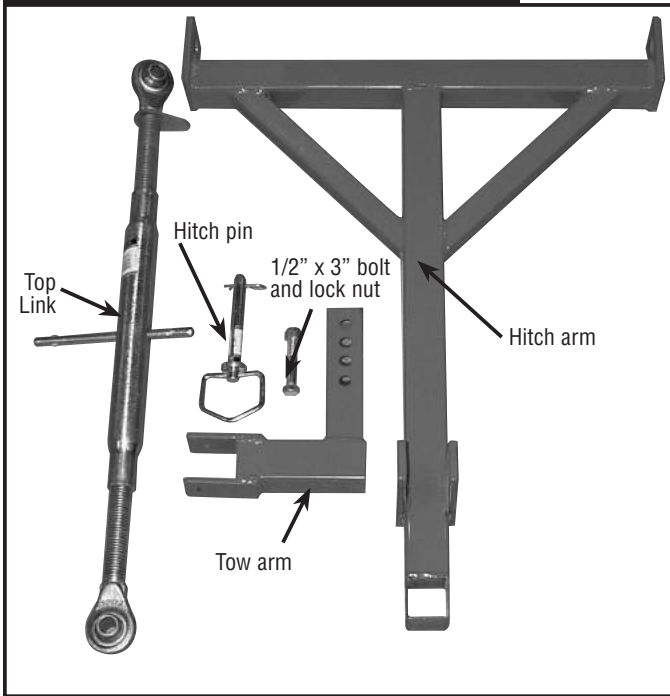

## STEP 8 (Optional Pull-behind Model Only) ASSEMBLY OF THE PULL-BEHIND TOW HITCH

See **STEP 8** photo before proceeding

1. The first step with the help of an assistant, is to remove the nuts and lock washers from the lift pins where the S-shaped hitch brackets attach to the A-frame.
2. Then carefully slide them out until they are flush with the inside of the S-brackets.
3. At this time place the hitch arm between the S-brackets and replace the nuts.
4. Next attach the top link to the top of the 3 point hitch **FIG 8A**.
5. Now lift the hitch arm up and connect it to the other end of the top link with the hitch pin **FIG 8B**.
6. In order to adjust the top link you need to insert the adjusting pin in the hole in the center of the top link and firmly tap it through with a hammer.
7. Now adjust the top link until the hitch arm is parallel to the A-frame.
8. Finally using the 1/2" x 4 1/2" bolt and lock nut attach the adjustable tow arm to the end of the hitch arm at the required height for your tow vehicle.

## STEP 8 PULL-BEHIND ATTACHMENT

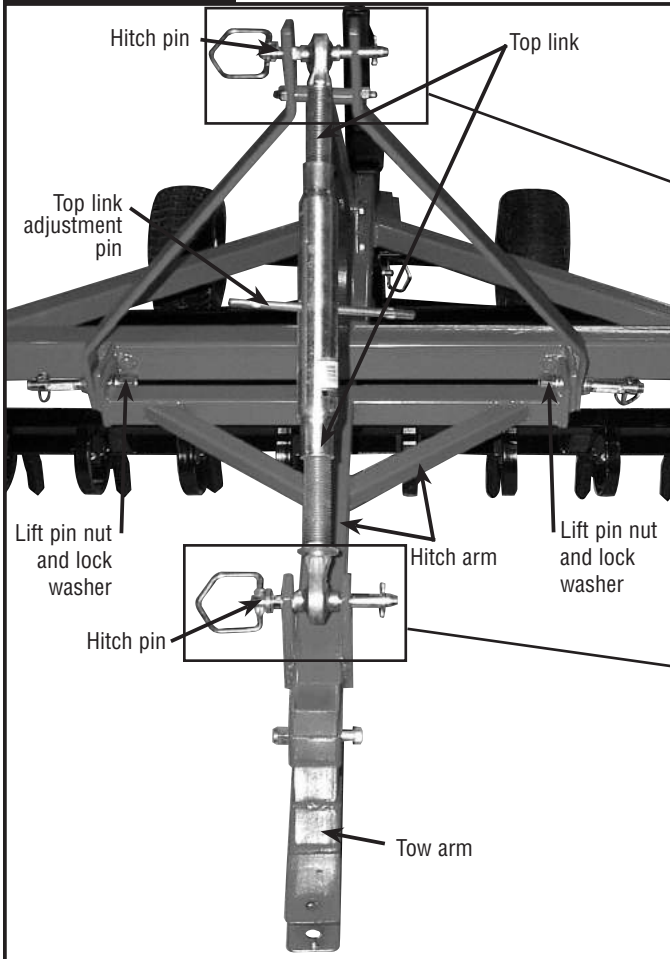

### FIG 8A

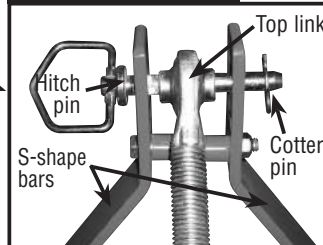

### FIG 8B

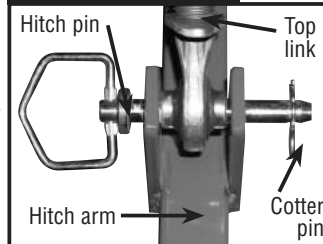

# OPTIONAL PULL-BEHIND ATTACHMENT ASSEMBLY (CONTINUED)

## PULL-BEHIND WHEEL ASSEMBLY

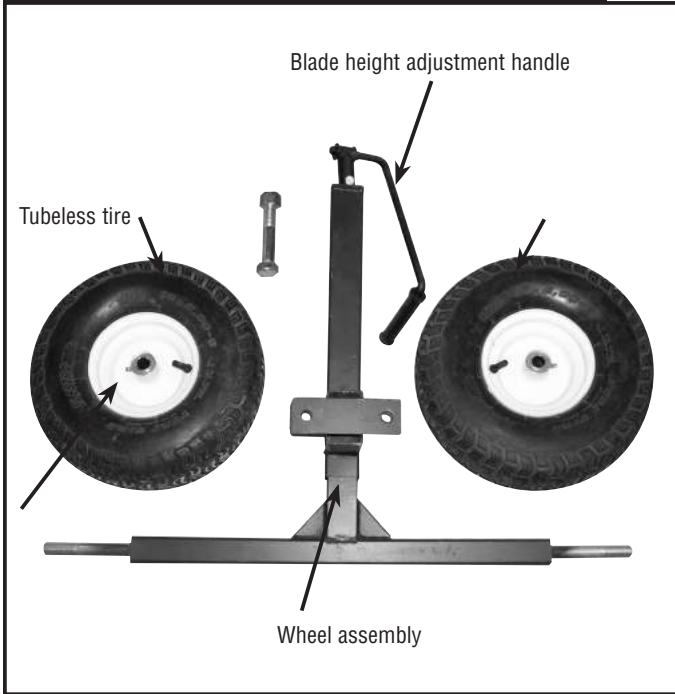

## STEP 9 (Optional Pull-behind Model Only) ASSEMBLY AND MOUNTING OF WHEEL ASSEMBLY

See **STEP 9** photo before proceeding

The final step is to assemble and mount the wheel assembly. Mount the wheels on the axles with grease nipples to the outside and tighten the nuts.

**NOTE:** Remember to grease the wheels periodically. Next attach the wheel assembly to the mounting bracket that is welded to the end of the A-frame with the two 1/2" x 1 1/2" bolts and lock nuts.

**NOTE:** The wheel assembly is used to raise the blade off the ground to prevent damage to the blade when traveling to and from your track or ring or anytime you are travelling over rough ground.

**NOTE:** If using the wheel kit on an existing Track & Ring Conditioner position and clamp the wheel assembly securely in place and drill a 1/2" hole through the mounting bracket hole and A-frame at 3" from the back of the A-frame.

## STEP 9

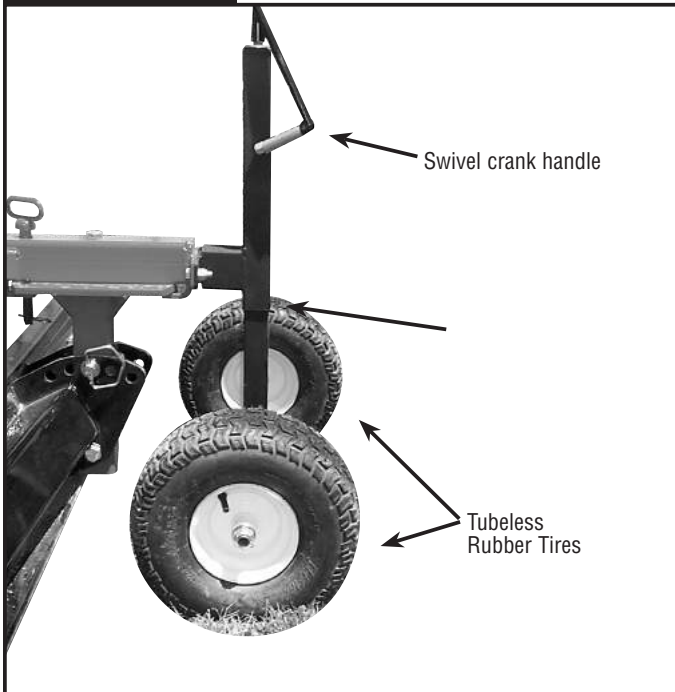

## TRACK & RING USAGE GUIDE

All the ideas below depend mostly on your particular footings. We will provide you with guidelines but after using the Conditioner, you will develop the settings for optimal results in your arena.

**VERY UNEVEN FOOTING:** First Time Use (Sand or similar material)  
Remember to never adjust the tines so deep as to disturb the sub base material. Penetration of the sub base will cause it to mix with the top footing material.

Adjust the tines 1" to 2" below the bottom level of the blade. Adjust the blade pitch to the 2nd setting (from the front). Having the blade at a 90° angle to the ground (or footing) will move material. Angle the blade to move the footing from the edges of the ring or track. It may take a few passes to get the outside build up out from the edges.

Make figure eights throughout the ring with irregular lines. This will move a larger amount of material into the lower spots and level out the high spots. To finish conditioning your area, rotate the blade to run parallel with the tines. Now travel from the outside of the ring making your way inward as you go.

## FREQUENTLY ASKED QUESTIONS

**Question:** Why do I need a Track and Ring Conditioner?

**Answer:** The Track and Ring Conditioner does a two step process in one step. Using chiseled harrow tines, the Conditioner breaks up clumped and packed footings. The second step is performed simultaneously by the leveling blade which follows the tines and smoothes the surface of a neat and even footing.

**Question:** Why are these tines useful?

**Answer:** We use a special "S" tine with a chisel point for an especially hard surface. The use of the tine is important not only of the breakup of hard material, but it also helps to aerate the soil. The tines are fully adjustable because almost every arena and track are different. In addition, the machine can be used for both arena and track with minimal changes to the machine itself.

**Question:** Is the blade adjustable?

**Answer:** The blade is fully adjustable by both pitch and angle. The angle adjustment allows the blade to be placed on an angle which allows material to be pulled away from the wall to the arena or from the edge of the track. This adjustability makes for a very flexible and convenient tool.

## REGULAR MAINTENANCE

Set the blade pitch to about a 45° angle. This way the blade will move some material and make a firmer surface. The tines should be adjusted 2" to 3" below the level of the blade. By doing this, the tines will help to loosen and aerate the footing. Work from the outside walls to the inside. Use of the tines will depend on how deep your footing is or how hard your footing is.

After using the Track & Ring Conditioner, you will develop your own way to do proper maintenance in a fraction of the time. The Track & Ring Conditioner will help to make safe, even footings for both horse and rider consistently.

The pitch is fully adjustable from 90° vertical to 180° horizontal. Different angles allows the user to control the amount of material being moved. To move material at once or to fill in sunken areas, a steeper angle is recommended. A lesser angle is recommended for general maintenance.

**Question:** Is the Track & Ring Conditioner easy to mount on my tractor?

**Answer:** The Track & Ring Conditioner has been designed to fit any Class 1 or 3 point hitch tractor.

**Question:** How is the Conditioner shipped?

**Answer:** The Track & Ring Conditioner is shipped crated and boxed. Easy to follow instructions and a complete hardware package allow anyone to assemble it in less than an hour.

**Question:** My arena is really uneven, will the Track & Ring Conditioner help?

**Answer:** Yes the first couple of times you use the Conditioner, you will have to travel in a figure eight pattern to move the material from the high spots into all of the low spots. Initially, if the surface is really bad it may take a while. However, if done on a regular schedule your maintenance time will be cut in half.

### TRACTOR SPECIFICATIONS for TRC-6 and TRC-8

- Horsepower rating . . . . . 20 - 60hp
- Hitch Type . . . . . class 1 or 3 pt.

### SPECIFICATIONS for TRC-PULL-BEHIND 6

- Horsepower rating . . . . . 350cc 4W or 20hp tractor
- Hitch Type . . . . . Tow Bar

## DEALER INFORMATION

TECHNICAL QUESTIONS CALL:

**1-800-461-3362**

or visit our website at: [www.systemequine.com](http://www.systemequine.com)